

# 2 Rotor Tedder

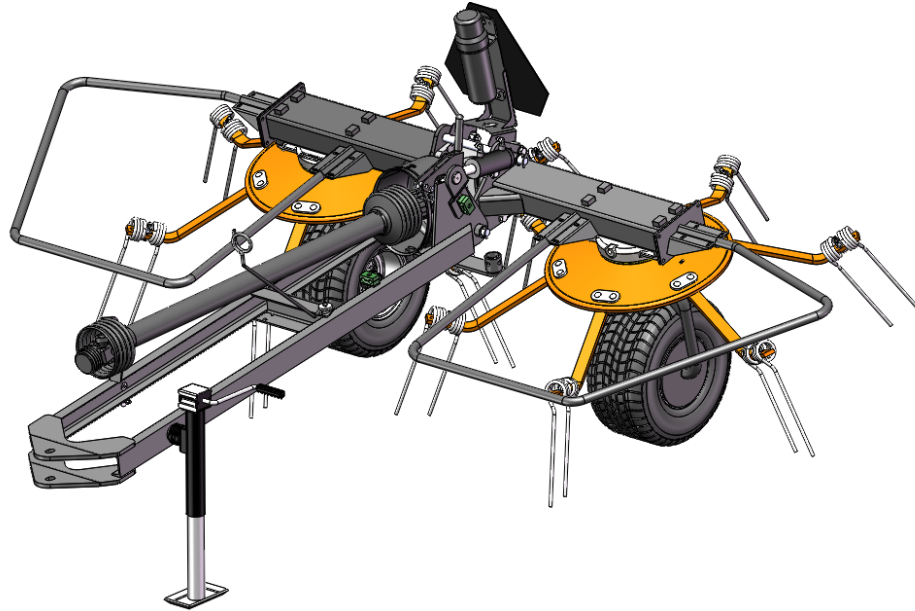

SPECIFICATIONS	
Number of Rotors	2
Tine Arms Per Rotor	6
Tine Arm Construction	1/2" x 1-1/2" Flat Bar
Working Width	9'
Tire Size	18.5 x 8
Wheel & Hub	4 Bolt Hub with Tapered Bearings
Hydraulic Tilt	Optional (with threaded rod for adjustment)
Rotor Spindle Pitch	Fixed
Rotor Gearbox	Enclosed Grease
Center Gearbox	Enclosed Oil Bath
Weight	700 lb

*Hydraulic Tilt (Optional Feature)*

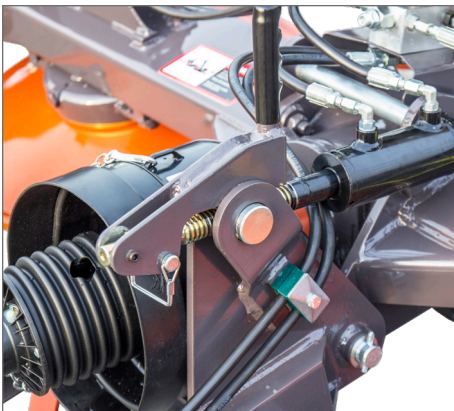

*Asymmetrical Tines (Even to Ground)*



*18.5 x 8 Tires on Real 4 Bolt Hubs*



**26X**

A Premium Tedder at a Value Price