



HR939 Rotary Rake

Illustrated Parts Breakdown

Page 1	Tongue & Main Frame
Page 2	Guards
Page 3	Gearbox & Tine Arm
Page 4	Axle Assembly
Page 5	Rotary Gearbox
Page 6	PTO Shaft

Tongue & Main Frame

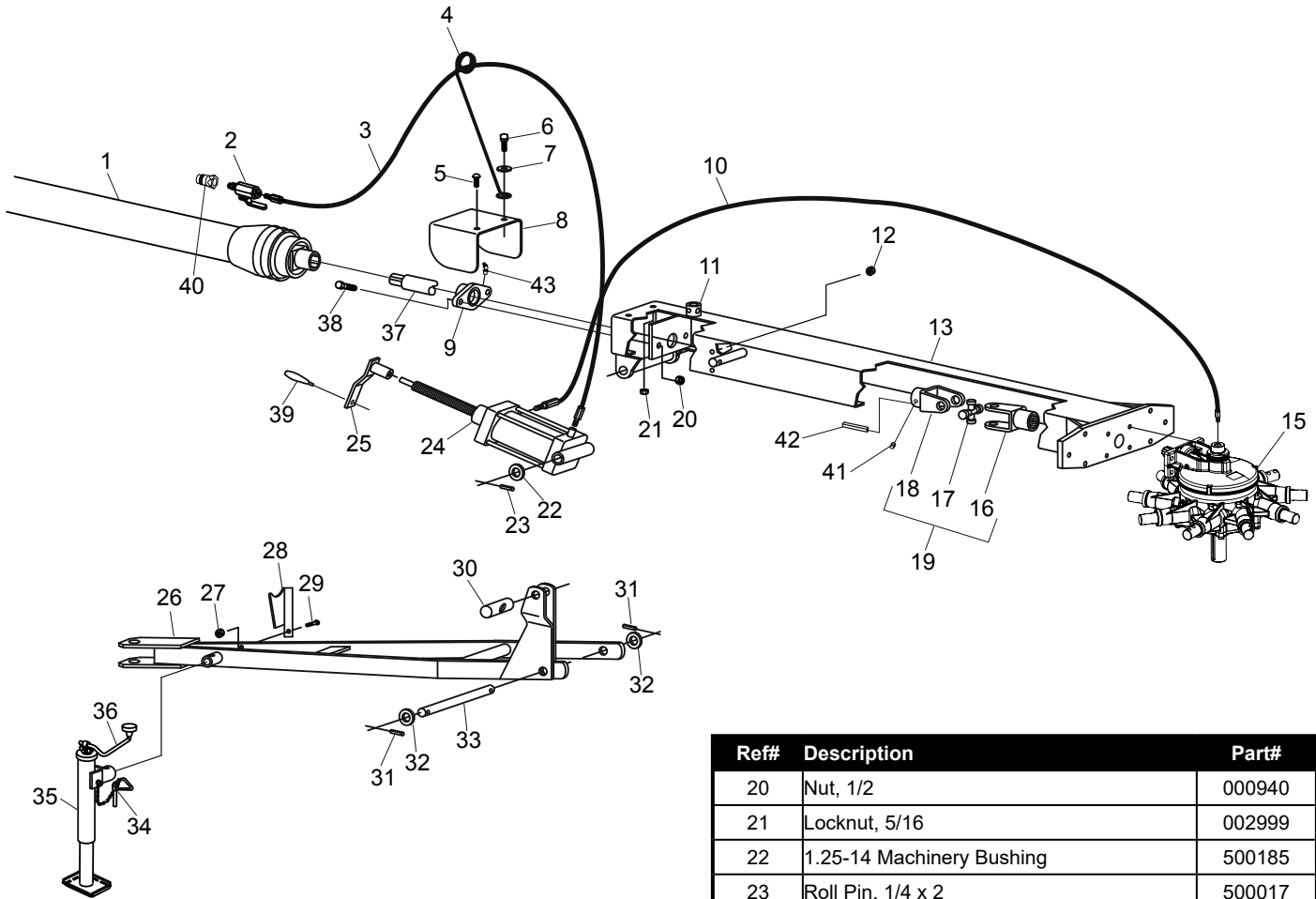

Ref#	Description	Part#
1	Complete PTO Shaft	503039
2	Ball Valve	502322
3	Hydraulic Hose, 89" (1/4" MP x 1/2"MP)	502294
4	Hose Support	502288
5	Bolt, 5/16 x 3/4 Truss Head	000210
6	Bolt, 5/16 x 1	000221
7	Hose Support Washer	502308
8	PTO Guard	502234
9	1-3/8 Flange Bearing	505568

Ref#	Description	Part#
20	Nut, 1/2	000940
21	Locknut, 5/16	002999
22	1.25-14 Machinery Bushing	500185
23	Roll Pin, 1/4 x 2	500017
24	Front Cylinder	502279
25	Front Cylinder Handle	503037
26	Tongue Assembly	502237
27	Locknut, 3/8	003000
28	PTO Stand	500015
29	Bolt, 3/8 x 1-1/4	000275
30	Cylinder Mount	502218
31	Roll Pin, 1/4 x 2	500017
32	1.25-14 Machinery Bushing	500185
33	Tongue Pin	502225
34	Pin & Chain	500012
35	Complete Jack	500009
36	Jack Handle	500010
37	Drive Shaft	502257
38	Bolt, 1/2 x 1-1/2	000435
39	Stainless Steel Handle	502149
40	Male Hydraulic Coupler	290105
41	Set Screw	500275
42	Key	500217
43	45° Grease Fitting, 1/4" Thread	701171

Guards

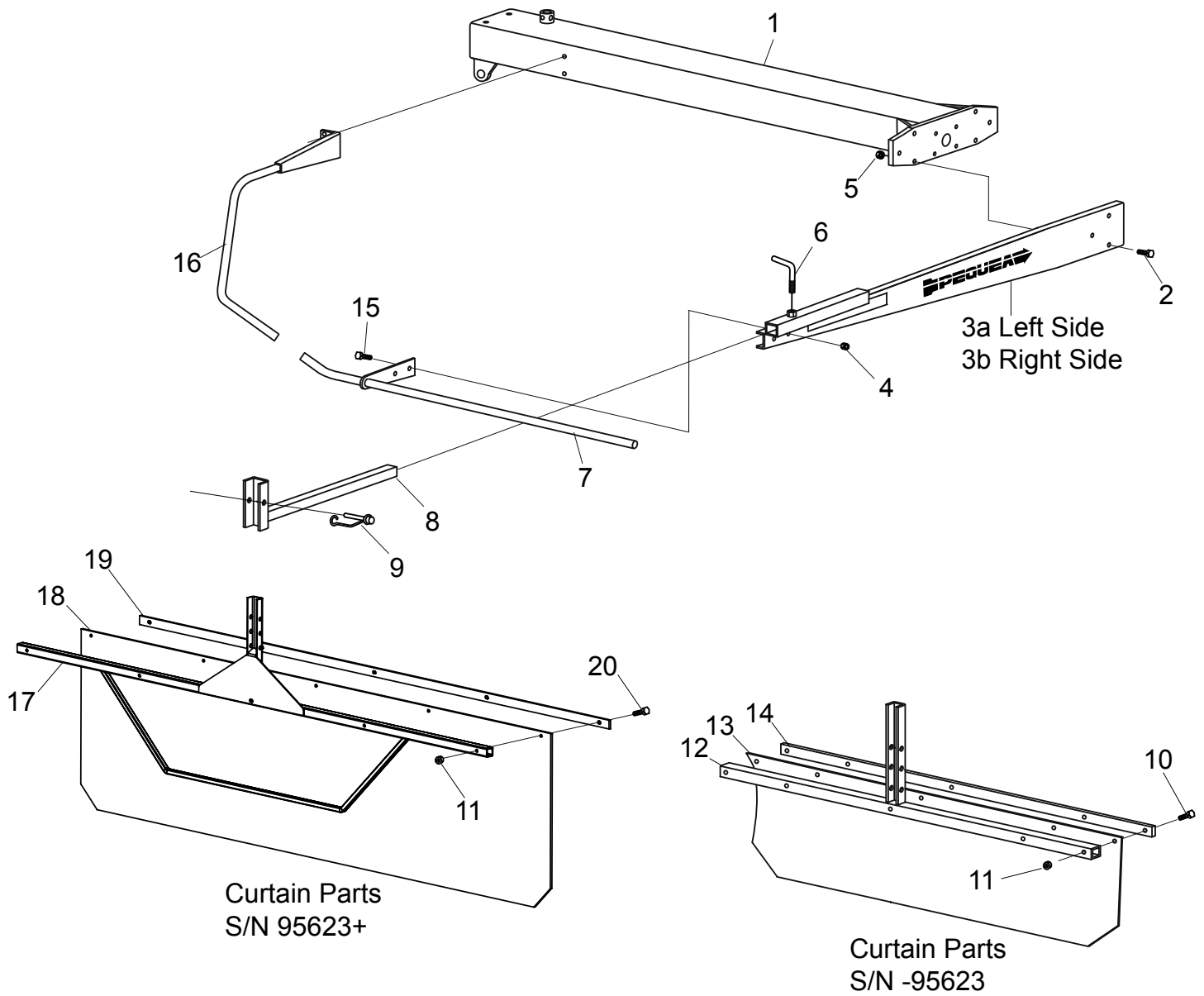

Ref#	Description	Part#
1	Tunnel Assembly	502204
2	Bolt, 1/2 x 1-1/4	000420
3a	Guard Arm, Left	502246
3b	Guard Arm, Right	502239
4	Nut, 3/8	000915
5	Nut, 1/2	000940
6	Curtain Set Bolt	500148
7	Tine Guard Assembly, Rear	503096
8	Telescoping Tube	500149
9	Snapper Pin	500158
10	Bolt, 1/4 x 1-3/4	000187

Ref#	Description	Part#
11	Locknut, 1/4	003001
12	Curtain Mount Assembly, S/N -800386	502251
13	Hay Curtain, S/N -800386	502252
14	Curtain Bar, S/N -800386	502247
15	Bolt 3/8 x 1	000270
16	Tine Guard Assembly, Front	503095
17	Curtain Mount Assembly, S/N 800386+	502372
18	Hay Curtain, S/N 800386+	500156
19	Curtain Bar, S/N 800386+	500155
20	Bolt, 1/4 x 2	000190

Gearbox & Tine Arm

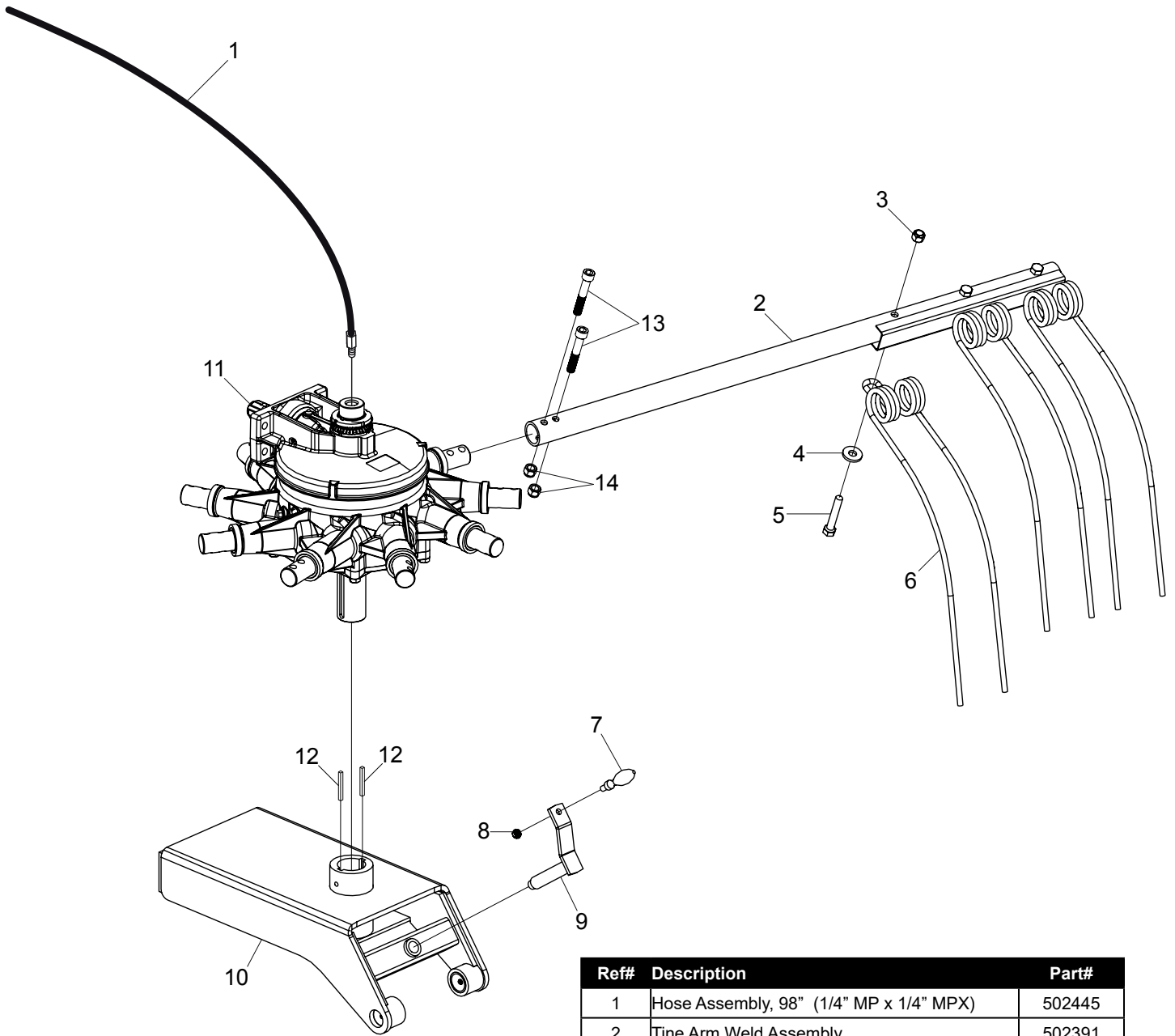

Ref#	Description	Part#
1	Hose Assembly, 98" (1/4" MP x 1/4" MPX)	502445
2	Tine Arm Weld Assembly	502391
3	1/2" x 3-1/4" Hex Head Bolt, Gr. 8	000478
4	Heavy Duty Flat Washer	000520
5	Locknut, 1/2	000950
6	Curved Rake Tine	500218
7	Stainless Steel Handle	502149
8	3/8" Nylon Jam Nut	000920
9	Rear Height Adjustment Handle	502274
10	Gearbox Stand Weld Assembly	502394
11	Complete Gearbox	502405
12	10 mm x 3.875" Key	502406
13	M12 x 70 Socket Head Bolt	002566
14	M12 Nylon Locknut	002824

Axle Assembly

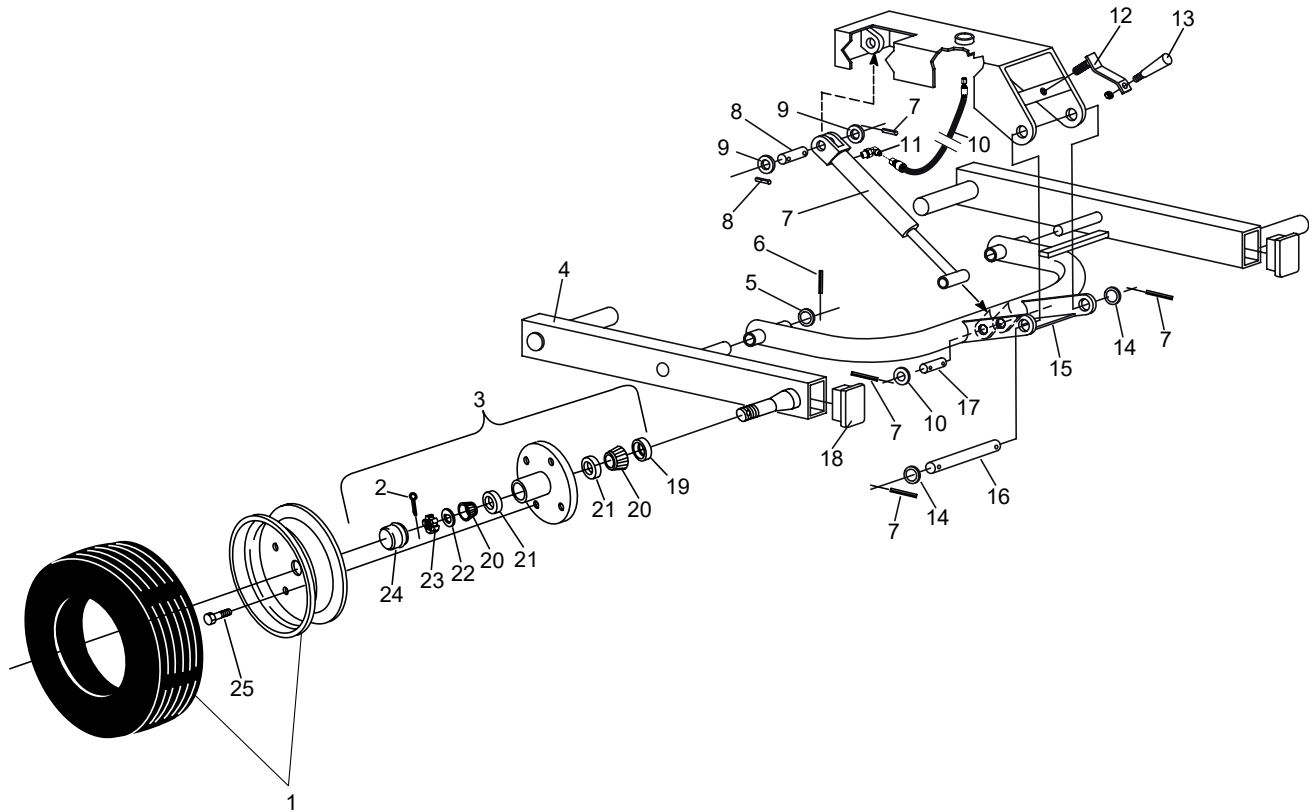

Ref#	Description	Part#
1	Rim & Tire Assembly	500220
2	Cotter Pin	500208
3	Complete Hub	500199
4	Walking Beam Assembly	502240
5	1.50-14 Machinery Bushing	500197
6	Roll Pin, 1/4 x 2	500017
7	Rear Cylinder	502278
8	Head/Cylinder Pin	502213
9	1.00-14 Machinery Bushing	001008
10	Hose Assembly, 98" (1/4" MP x 1/4 MPX)	502445
11	Elbow Fitting, 1501L-4-4	502301
12	Rear Height Adjustment Handle	502274
13	Stainless Steel Handle	502149
14	1.25-14 Machinery Bushing	500185
15	Axel Assembly	502243

Ref#	Description	Part#
16	Gearbox Stand/Axle Pin	503048
17	Axle/Cylinder Pin	502212
18	Plastic End Cap	502276
19	Grease Seal	500201
20	Bearing, LM44643	500202
21	Race, LM44610	500204
22	Spindle Washer	500206
23	Spindle Nut	500207
24	Dust Cap	500209
25	Lug Bolt, 1/2 x 20	500220

Rotary Gearbox

Ref#	Description	Part#
1	Locknut	502408
2	Shim, 0.5mm x 57.5mm x 2mm	502409
3	Spring Washer	502410
4	Upper Key, 10mm x 8mm x 50mm	502411
5	Main Shaft	502412
6	Lower Key,	502406
7	Upper Housing	502413
8	M10 x 16 Socket Head Bolt, Gr. 8.8	502414
9	Ring Gear	502415
10	Internal Retaining Ring	502416
11	Shim	502417
12	Ball Bearing, 6310 2RS	502418
13	Shim	502419
14	External Retaining "Ring	502420
15	Lower Housing	502421
16	Oil Seal, 35mm x 45mm x 7mm	502422
17	Crank Arm Shaft (with cam roller)	502423
18	Crank Arm Shaft Spacer	502424
19	Crank Arm Shaft Shim	502425
20	Double Lip Seal	502426
21	Cam	502427
22	Lower Bearing, 6210	502428
23	Oil Seal, 50 x 72 x 8	502429
24	Lower Cap	502430
25	Hex Head Bolt, M10 x 25 Gr. 8.8	502431
26	Plug	502432
27	Pinion Shaft	502433
28	Shim, 35.3 x 48.0	502434
29	Shim, 49 x 71, 7x0,2	502435
30	External Snap Ring, Pinion Shaft	502436
31	Internal Snap Ring, Pinion Shaft	502437
32	Pinion Bearing, 6207	502438
33	Pinion Oil Seal	502439
34	Cam Lock	502440
35	Bolt, M10 x 22 Gr. 8.8	502441
36	Grease Fitting, M10 x 1	502442
37	Needle Bearing, Pinion Shaft	502443
38	Key, 10 x 8 x 35	502444
	Complete Gearbox	502405

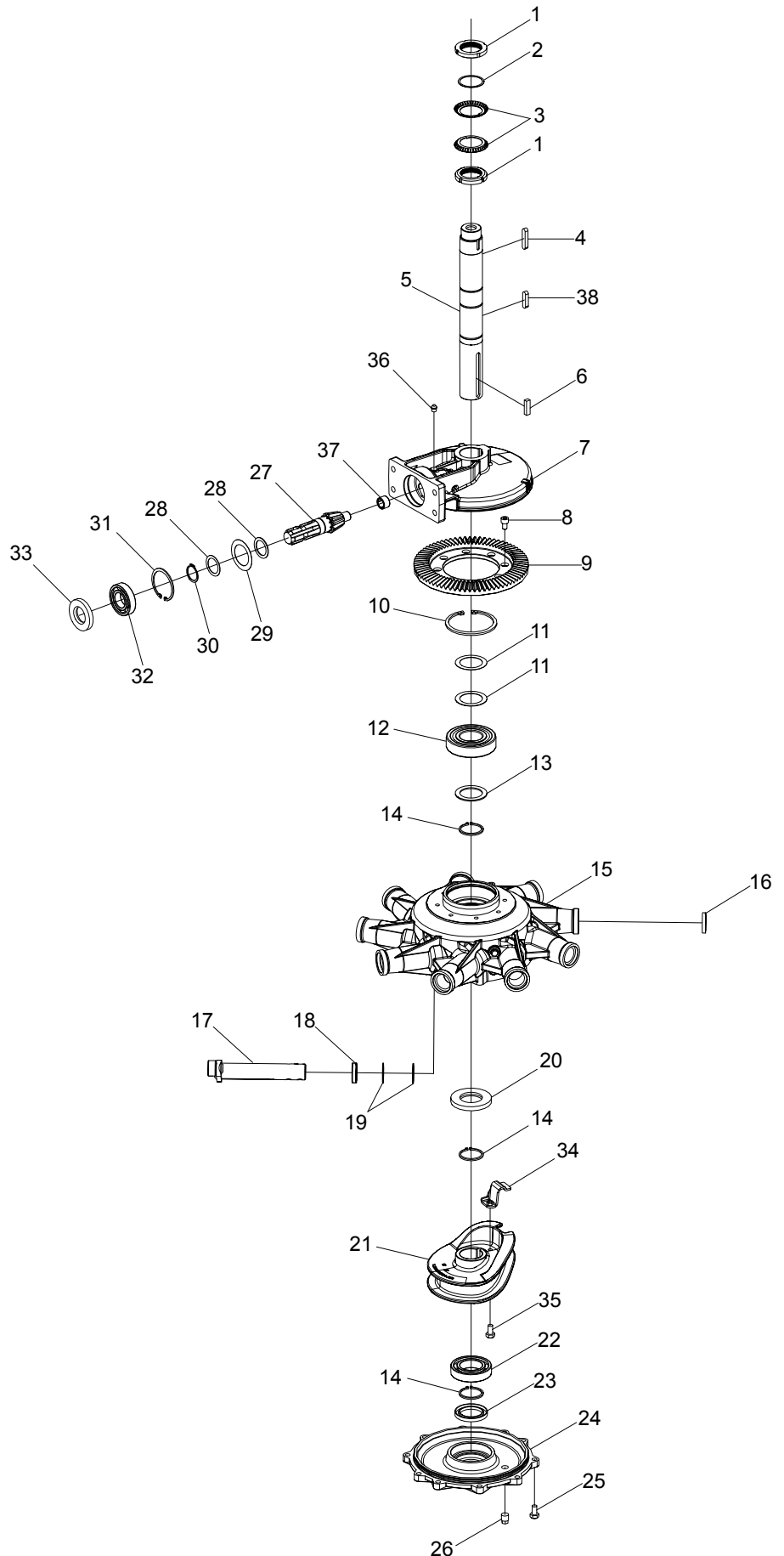

PTO Shaft Assembly

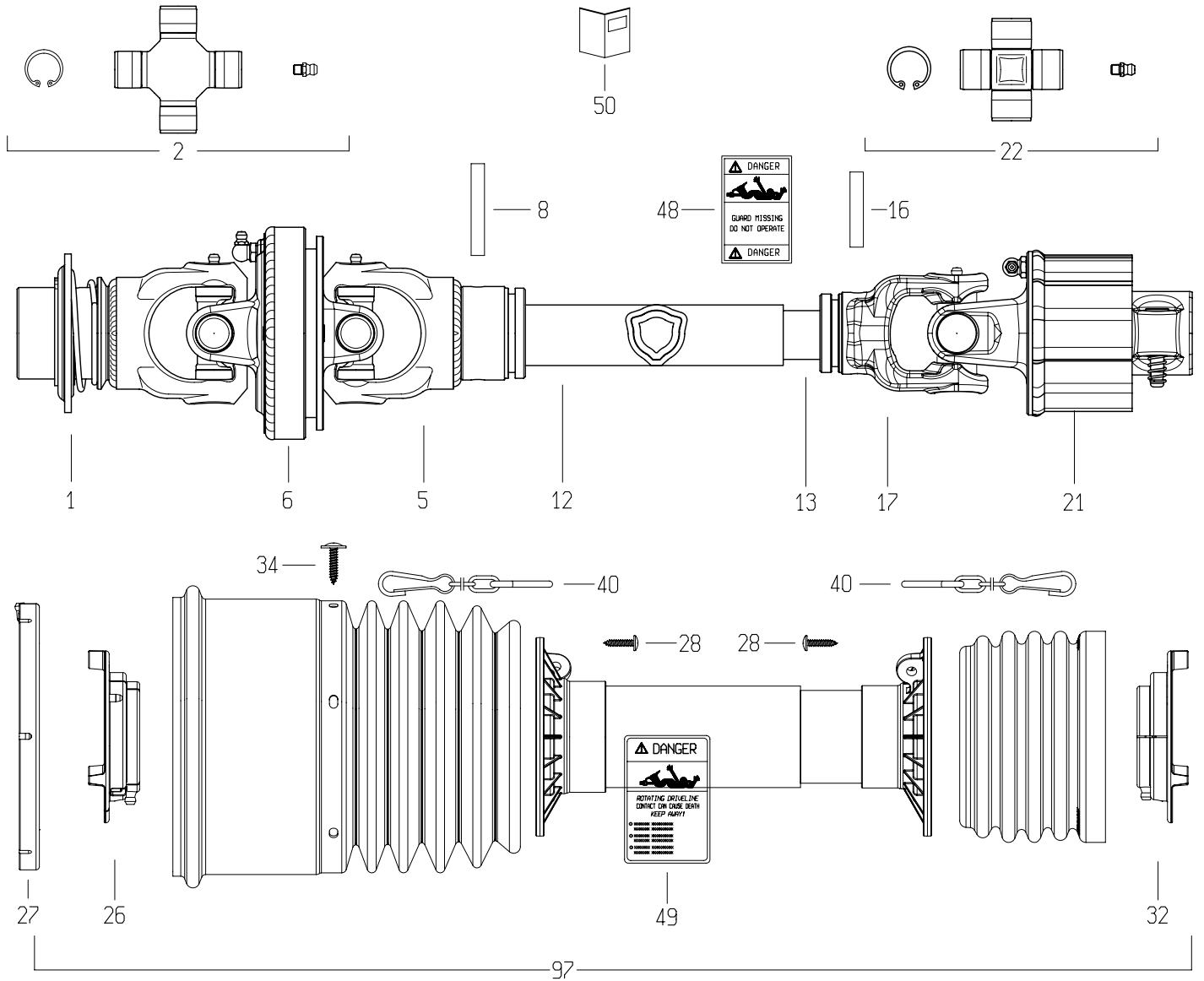

Ref#	Description	Part #
1	Yoke S2 Rt 1-3/8"Z6 80°Cv	503100
2	Cross Kit S2 EI 80°Cv 22X76 Zerk In Cap	503101
5	Yoke G2 Outer Tube (36.0) 80°Cv EI	503102
6	Central Body 1R2-G2-S2 80°Cv EI	503103
8	Flexible Roll Pin 8X55 Din1481	500433
12	Cardan Tube Outer 12518 L=770	503117
13	Cardan Tube Inner 12504 L=770 Rilsan.	503118
16	Flexible Roll Pin 8X45 Din1481	903327
17	Tube Yoke #2-G2 Inner (29.0)	503106
21	Sa2/2 Dx *400 Nm* 1 3/8" Z=6 Puls.	503119

Ref#	Description	Part #
22	Cross Kit S2-G2 23.8X61.3 Cap Zerk	503108
26	Shield Support G2 Outer Global	503109
27	Shield Support S2-S4 EI Cv 80° & 50°	503110
28	Screw 4.8X22 Self Tap Zinc	500417
32	Shield Support G2 Inner Global	503111
34	Screw 4.8X22 Self Tap Zinc Flange Head	503112
40	Shield Chain W/S-Hook L=500Mm	500420
48	Label - Danger - Outer Drive Tube	500421
49	Label - Danger - Outer Shield Tube	500422
50	Instruction Booklet - N.america Global	500423
97	Complete Shield Kit	505797